



Technical File

Chapter 5 - Ceilings

Cement-bonded particleboards
Agglomerated particle board with cement

Office

Av. Infante Dom Henrique 337, 3rd Floor
1800- 210 LISBON, PORTUGAL

Factory

VIROC Portugal S.A.
National Road 10
Km 44.7, Vale da Rosa
2914-519 SETÚBAL, PORTUGAL

In/ investwood

www.investwood.pt

INDEX

5.	FALSE CEILINGS	5
5.1	General features	5
5.2	Fasteners	6
5.3	Support structure	6
5.3.1	Wooden beams	6
5.3.2	Galvanised steel profiles	7
5.3.3	Aluminium profiles	8
5.3.4	Supporting squares	9
5.3.5	Threaded rod + pivots	9
5.4	Panel installation	10
5.4.1	Outdoors	10
5.4.2	Indoors	11
5.5	Surface treatment	12
5.6	Paints and varnishes	12
5.7	Joints between panels	12
5.8	Ceiling type sections	13
5.9	Acoustic performance	15
5.9.1	Ceiling with 100 mm box (Dx=100 mm)	16
5.9.2	Ceiling with 200 mm box (Dx=200 mm)	16
5.9.3	Ceiling with 400 mm box (Dx=400 mm)	16

INDEX TO TABLES AND FIGURES

Figure 5.1 - Screws for fixing Viroc panels to ceilings indoors and outdoors	6
Figure 5.2 - Screws for fixing Viroc panels to indoor ceilings	6
Figure 5.3 - Wooden beams	7
Figure 5.4 - Galvanised steel profiles	7
Figure 5.5 - Galvanised steel profiles (Alternative)	8
Figure 5.6 - T47 profile (minimum thickness: 0.7mm)	8
Figure 5.7 - Aluminium structure	9
Figure 5.8 - Detail of panel attachment to support profile	9
Figure 5.9 - Pivot for fixing the support profile to the threaded rod	10
Figure 5.10 - Roof panel fixings, applied outdoors	10
Figure 5.11 - Torque limiting knobs, to be placed on the riveting head	11
Figure 5.12 - Screw-centering spanner	11
Figure 5.13 - bolt hole centering spanner	11
Figure 5.14 - bolt hole centering tool, SFS Intec	11
Figure 5.15 - Ceiling panel fixings, applied indoor	12
Figure 5.16 - Roof with wooden structure	13
Figure 5.17 - Roof with galvanised steel structure	13
Figure 5.18 - Roof with galvanised steel TC structure	14
Figure 5.19 - Roof with aluminium structure	14
Figure 5.20 - Panel 1250x600 mm, with 12 mm diameter holes 32 mm apart between the axes	15
Figure 5.21 - Ceiling section, from the experimental tests carried out to determine the sound absorption index	15

Credits

Author

Mr José Pinheiro Soares,
suporte.tecnico@investwood.pt

Review

CS Traduções
geral@cstraducoes.pt

Viroc Portugal S.A. reserves the right to modify this document without prior notice.

This Technical File invalidates all previous technical documents.

Issue: 15 February 2024

5. FALSE CEILINGS

Viroc panels can be used as a cladding element for a false ceiling. The support structure is made of galvanised steel or wood, with equidistant supports, the distance between which must not exceed 600 mm.

It is the installer's responsibility to check the safety conditions of the support structure, in particular the distance between the supports and the size of the supports for correct installation of the panels.

Viroc panels undergo small dimensional variations with changes in relative moisture and temperature. The Viroc panel can be expected to accommodate a maximum dimensional variation of -0.1% (shrinkage) to +0.05% (expansion) in an interior application and -0.3% (shrinkage) to +0.1% (expansion) in an exterior application.

The panel fixings must take this into account.

5.1 General features

Application

Interior and exterior

Thicknesses

10 mm in dry indoor areas;

12 mm in moist outdoors or indoor areas such as bathrooms and kitchens.

Maximum panel size

3000x1250 mm.

Any intermediate dimensions obtained by cutting the standard dimension panel are possible.

Panel thickness tolerances

Thickness: 10 mm \pm 0.7 mm; 12 mm \pm 1.0 mm

Cutting tolerances

Length and width: \pm 3 mm

Squaring: \leq 2 mm/m

Edge straightness: \leq 1.5 mm/m

5.2 Fasteners

The panels are fixed with screws or rivets suitable for wooden or metal structures.

Figures 5.1 and 5.2 show the screws and rivets that can be used to fix Viroc panels to ceilings.

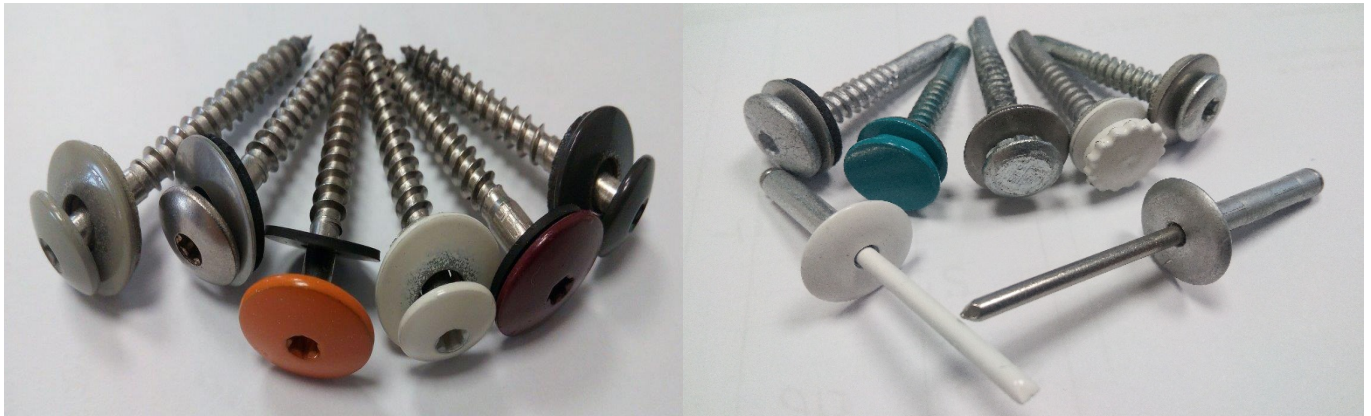

Figure 5.1 - Screws for fixing Viroc panels to ceilings indoors and outdoors.



Figure 5.2 - Screws for fixing Viroc panels to indoor ceilings

The location of the screws and the diameter of the bolt holes in the panels must be as shown in figure 5.10 if the ceiling is to be installed outdoors or 5.15 if the ceiling is to be installed indoors.

5.3 Support structure

The support structure can be made of metal or wooden profiles, connected to the ceiling using rigid elements such as supporting squares or flexible ones using threaded rods.

5.3.1 Wooden beams

The profiles supporting the panels can be made of pine wood. The strength of the wood used to make up the uprights must be at least of class C18 according to EN 338 and durability of class 2, 3 or higher according to EN 335.

When assembled on site, wooden uprights must not have a moisture level of more than 18%, with a difference between consecutive elements of no more than 4%. The relative moisture of the wooden uprights is determined according to the method described in standard EN 13183-2, using a tip moisture metre.

The cross-section of the support profiles is generally rectangular, with a minimum dimension of 40x50 mm (see figure 5.3).

The design of these elements must take into account the deformations caused by the actions (self-weight, overloads, etc.), so that they do not jeopardise the normal functioning of the roof. Deformation due to action must not exceed the limit $L/200$ of the span between support fixings.

The width of the uprights must be such that the fixings can be positioned correctly, with the capacity to absorb small positioning errors; the screws must not be less than 15 mm from the end of the upright.

Other types of sections can be used, as long as they have the same performance and durability.

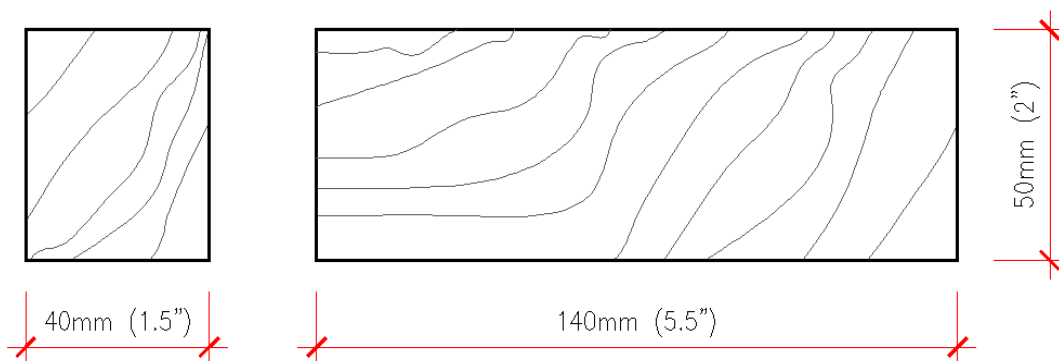

Figure 5.3 - Wooden beams

Minimum resistance of class C18 (EN 338)

5.3.2 Galvanised steel profiles

The galvanised steel profiles are fixed to the load-bearing structure using galvanised or stainless steel supporting squares, with metal anchors or anchors made up of metal screws and plastic bushes.

The minimum strength of the steel used in the upright profiles must be of class DX51D, in accordance with standard EN 10346.

The hot-dip zinc coating (Z) must be 275 g/m² in coastal areas and 140 g/m² in other areas.

The section of the profiles is generally Omega, C or L-shaped with a recommended thickness of 1.5 mm. Other profile shapes can be used; provided they have the same performance and durability (see figures 5.4 and 5.5).

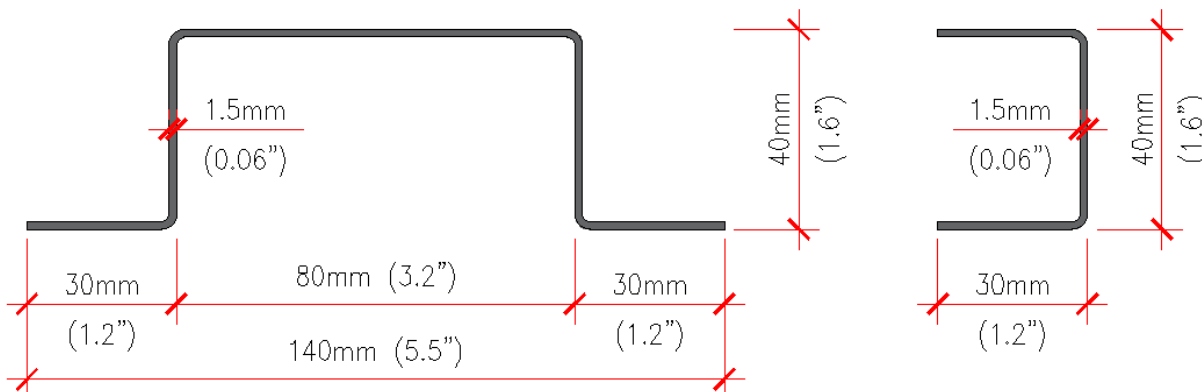

Figure 5.4 - Galvanised steel profiles

Minimum resistance of class DX51D (EN 10346)

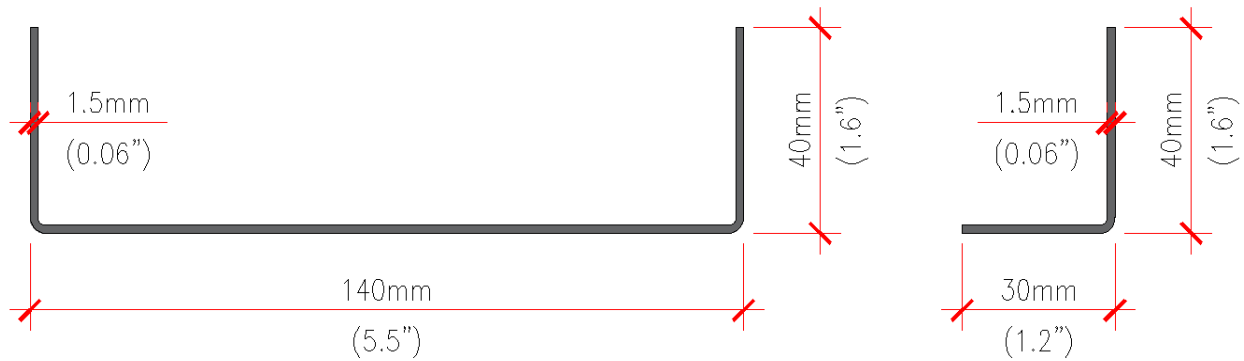

Figure 5.5 - Galvanised steel profiles (Alternative)
Minimum resistance of class DX51D (EN 10346)

The profile system used in plasterboard ceilings (T47 or similar) can be used if the Viroc panels are fixed with rivets (see figure 5.6), or if they have a thickness that guarantees the anchorage of the screws. In ceilings applied outdoors, the minimum thickness for fixing the screws is 1.5 mm; therefore these profiles are not suitable.

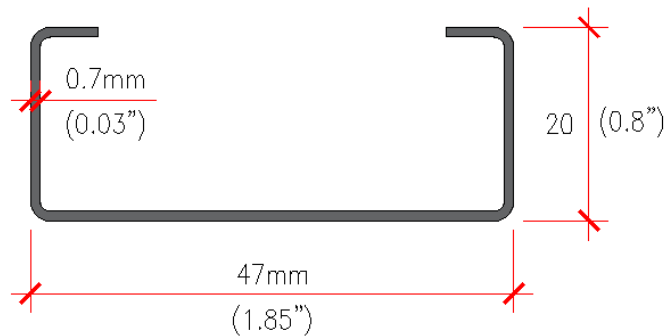

Figure 5.6 - T47 profile (minimum thickness: 0.7mm)
Galvanised steel: DX51D (Z+)

The support profiles must be dimensioned taking into account the deformations caused by the actions (self-weight, overloads, etc.), so that these do not jeopardise the normal functioning of the roof. Deformation due to action must not exceed the L/200 limit of the span between support fixings.

The width of the profiles must be such that the fixings can be positioned correctly, with the capacity to absorb small positioning errors, and the screw must not be less than 10 mm from the end.

The distance between profiles must respect the maximum distance between panel fixings, and the alignment of profiles between adjacent elements must be checked and must not differ by more than 2 mm.

5.3.3 Aluminium profiles

The aluminium profiles are fixed to the load-bearing structure using aluminium supporting squares, with metal anchors or anchors made up of metal screws and plastic bushings.

The aluminium used in the profiles must be at least a 6000 series alloy, with a yield strength $R_{p0.2}$ greater than 180 MPa.

The section of the profiles is generally T or L-shaped with a minimum thickness of 2 mm. Other section shapes can be used, provided they have the same performance and durability.

T-shaped profiles are used at the intersection of 2 panels. L-sections are used as intermediate supports and are also used to create single points on the façade (see figure 5.7).

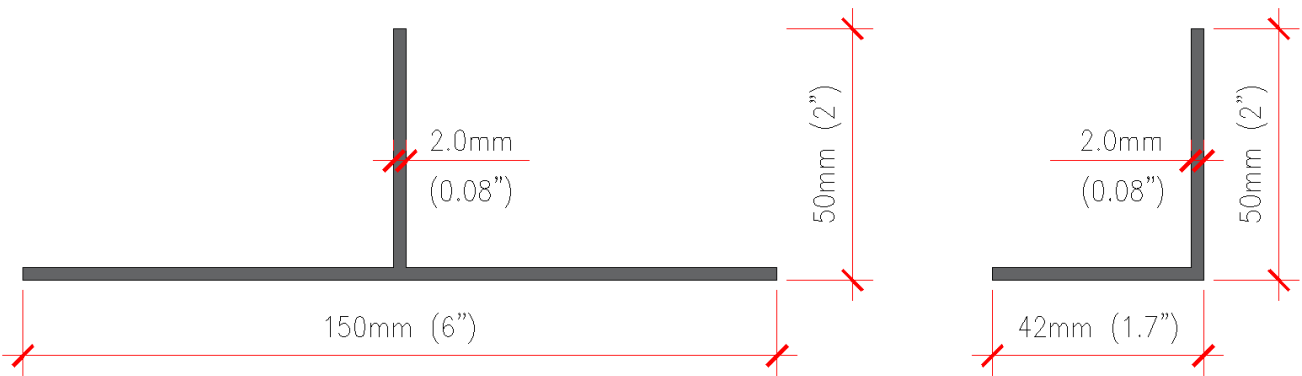

Figure 5.7 - Aluminium structure
6000 series alloy with $Rp0.2 \geq 180$ MPa

The support profiles must be dimensioned taking into account the deformations caused by the actions (self-weight, overloads, etc.), so that these do not jeopardise the normal functioning of the roof. Deformation due to action must not exceed the $L/200$ limit of the span between support fixings.

The width of the profiles must be such that the fixings can be positioned correctly, with the capacity to absorb small positioning errors, and the screw must not be less than 10 mm from the end.

The distance between profiles must respect the maximum distance between panel fixings; the alignment of profiles between adjacent elements must be checked and must not differ by more than 2 mm.

5.3.4 Supporting squares

The support structure can be fixed using galvanised steel or aluminium supporting squares, depending on the type of structure. Galvanised steel supporting squares can be used with wooden or galvanised steel frames, while aluminium supporting squares can be used with aluminium profiles.

5.3.5 Threaded rod + pivots

The support structures used in the plasterboard panels consist of threaded rods fixed to the ceiling with bushings and pivots to the metal profiles (see figures 5.8 and 5.9).

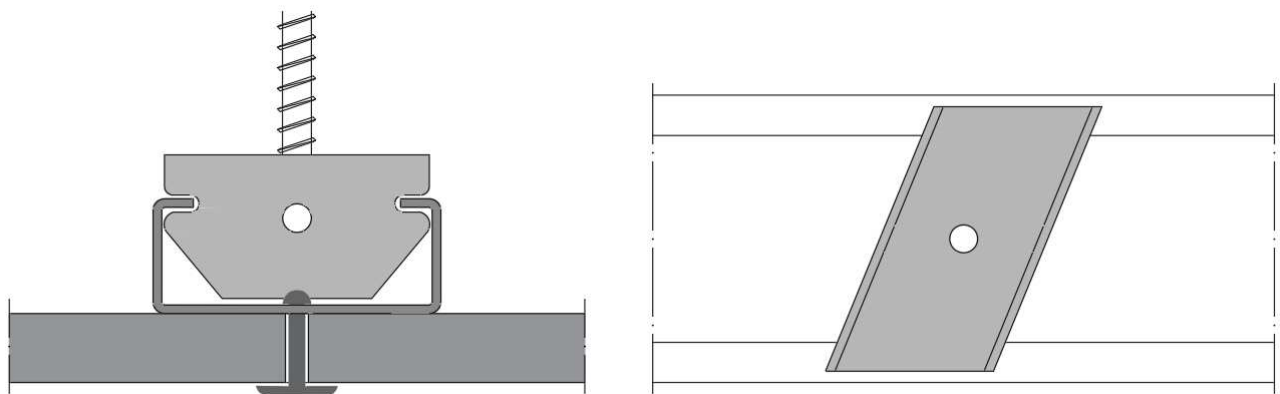

Figure 5.8 - Detail of panel attachment to support profile



Figure 5.9 - Pivot for fixing the support profile to the threaded rod

5.4 Panel installation

5.4.1 Outdoors

In order to allow for dimensional variations in the panels, it is necessary to drill holes in the panels to allow for this behaviour, so as to maintain their integrity.

For the panel peripheral fixings, the diameter of the bolt holes must be 10 mm larger than that of the screw body, to allow for shrinkage and expansion. In the supports in the central zone, the diameter of the bolt holes should be 5 or 5.5 mm, the same as the body of the screw, fixing the panel rigidly (see figure 5.10).

Its function is to ensure the proper positioning of the panels and to allow dimensional variations without introducing stress. Fastening is carried out from the fixed supports in order to position the panel.

Expansion supports are only built later to avoid introducing stresses.

Fixings near the periphery of the panels must be made at a distance of 50 to 75 mm.

Care must be taken not to over-tighten the screws in order to block dimensional variations, using screwdrivers with depth limiters. Excessive tightening can block the expansion and contraction of the panels and cause breakage at the corners and edges.

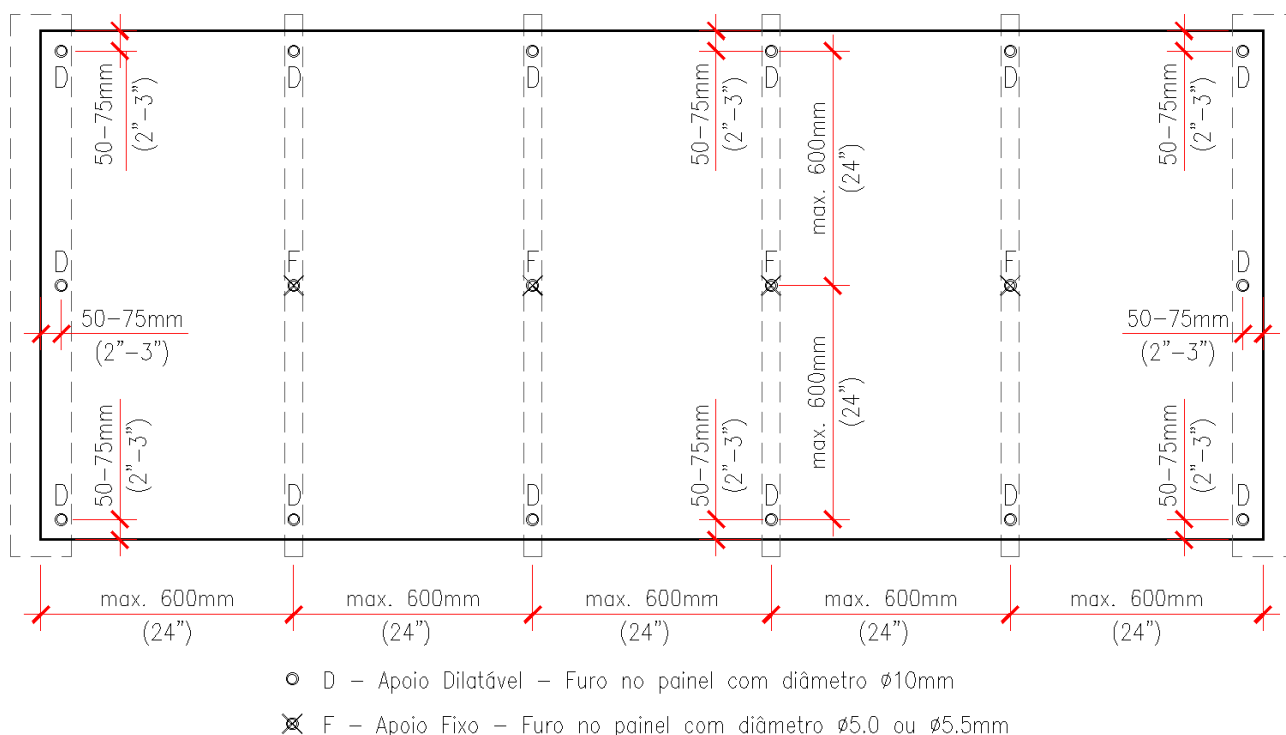

Figure 5.10 - Roof panel fixings, applied outdoors

When fastening with rivets, it is necessary to use a spacer, which is placed on the head of the riveting machine so as to leave a gap of 0.5 mm between the surface of the panel and the back of the rivet head. This free space is used to create a gap and allow for dimensional variations in the panels (see figure 5.11).



Figure 5.11 - Torque limiting knobs, to be placed on the riveting head

To make it easier to place the screws or rivets in the centre of the bolt holes, auxiliary tools can be used (see figures 5.12 and 5.14).



Figure 5.12 – Screw-centering spanner
SFS Intec



Figure 5.13 - bolt hole centering spanner
SFS Intec: ZL, ETANCO: ML 1000

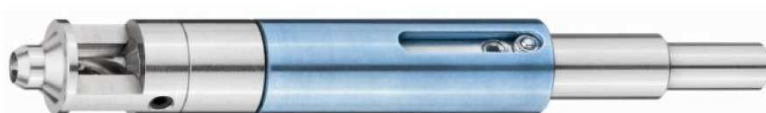

Figure 5.14 – bolt hole centering tool, SFS Intec

5.4.2 Indoors

In indoor applications, if the temperature and moisture variations are not important, the panels can be fixed only with supports, making fixing work easier.

The panels can always be drilled with the same bolt holes diameter, 5 or 5.5 mm depending on the diameter of the screws, whether they are located in the centre of the panel or on the periphery.

The fixings near the periphery of the panels are made at a distance of 50 to 75 mm (see figure 5.15).

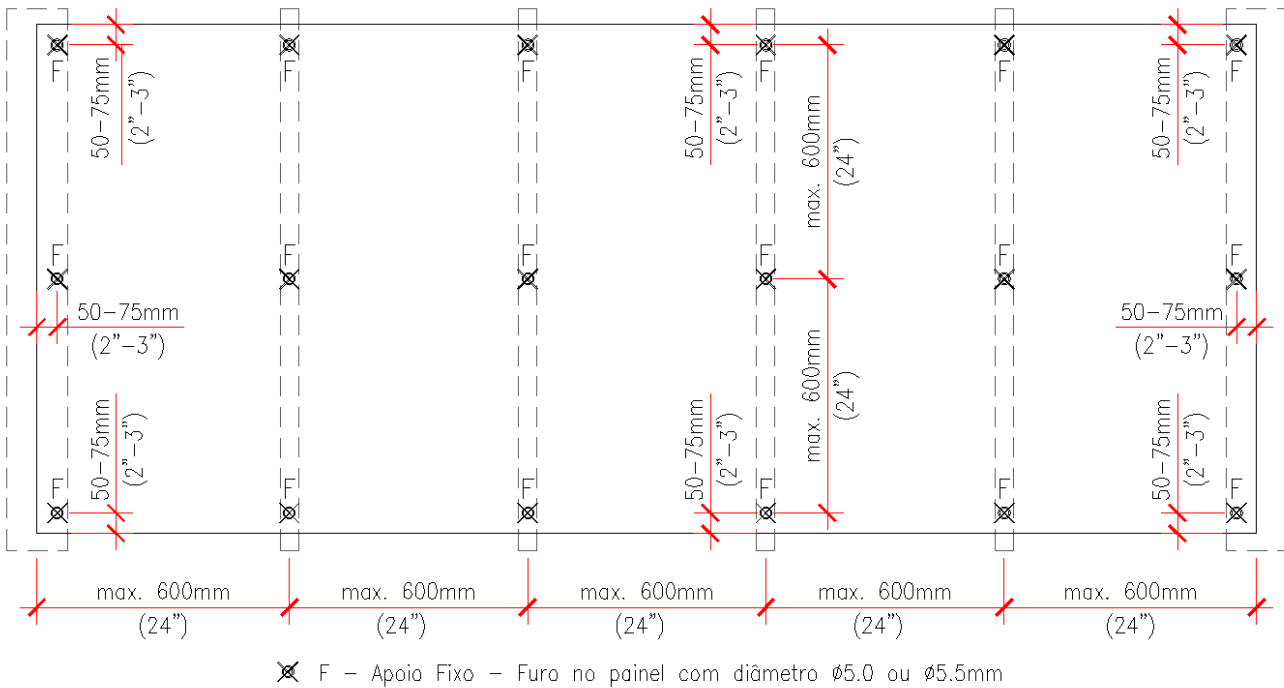

Figure 5.15 - Ceiling panel fixings, applied indoor

5.5 Surface treatment

Panels applied outdoors must be protected with paint or varnish.

Before applying the varnish to the panels, the surfaces must be completely clean and dry, with no grease, dust or salts. Cleaning can be done by polishing with cleaning disks. VIROC Portugal has suitable disks that it can supply on request. Alternatively, the surfaces can be cleaned using sandpaper with a fine-grained disk equal to or greater than 120.

5.6 Paints and varnishes

There are no specific paints or varnishes to be applied to Viroc. The panel has a surface alkalinity (PH) of 11 to 13, so paints and varnishes suitable for concrete and wood surfaces at the same time are usually the best when applied to Viroc panel.

Paints and varnishes made from acrylic resins or solvent-based aliphatic polyurethanes are the ones that have shown the best performance.

Water-based acrylic resin or aliphatic polyurethane varnishes have the least effect on the panel original colour.

Generally speaking, varnishes are easy to apply, but it is very important to bear in mind that the application must be continuous and constant, to guarantee the homogeneity of the finish on the panel and so that the surface doesn't become stained and have different shades. Panels must always be painted/varnished on both sides and tops. The application procedures provided by the manufacturers must always be followed for the recommended coats.

5.7 Joints between panels

The joints between panels should have a gap of 2 to 3 mm when applied indoors and 5 mm when applied outdoors.

5.8 Ceiling type sections

Figures 5.16, 5.17, 5.18 and 5.19 show roof sections made with different types of structure.

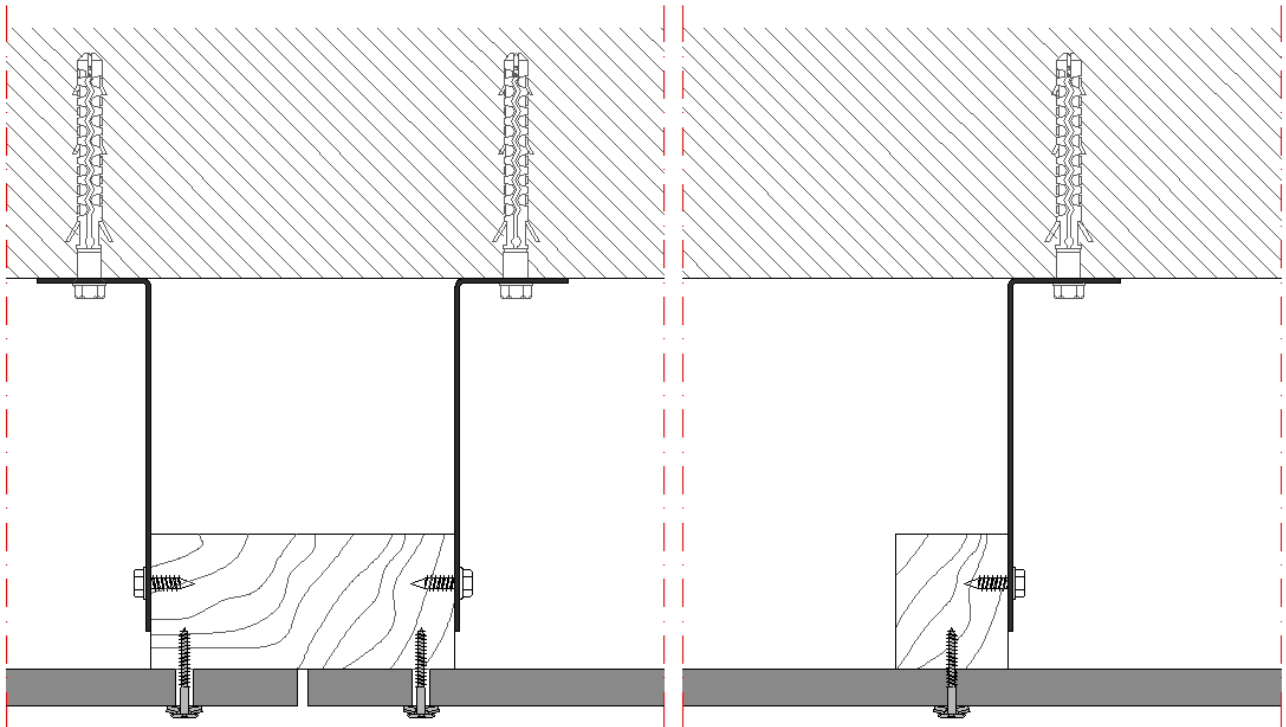

Figure 5.16 - Roof with wooden structure

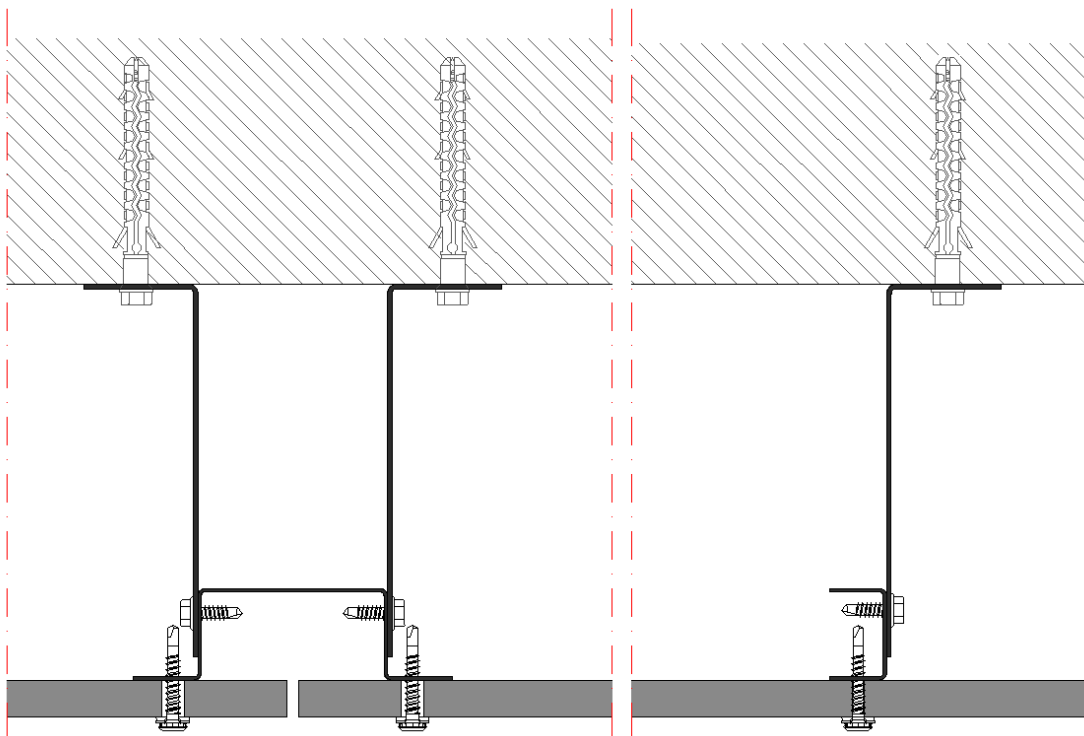

Figure 5.17 - Roof with galvanised steel structure

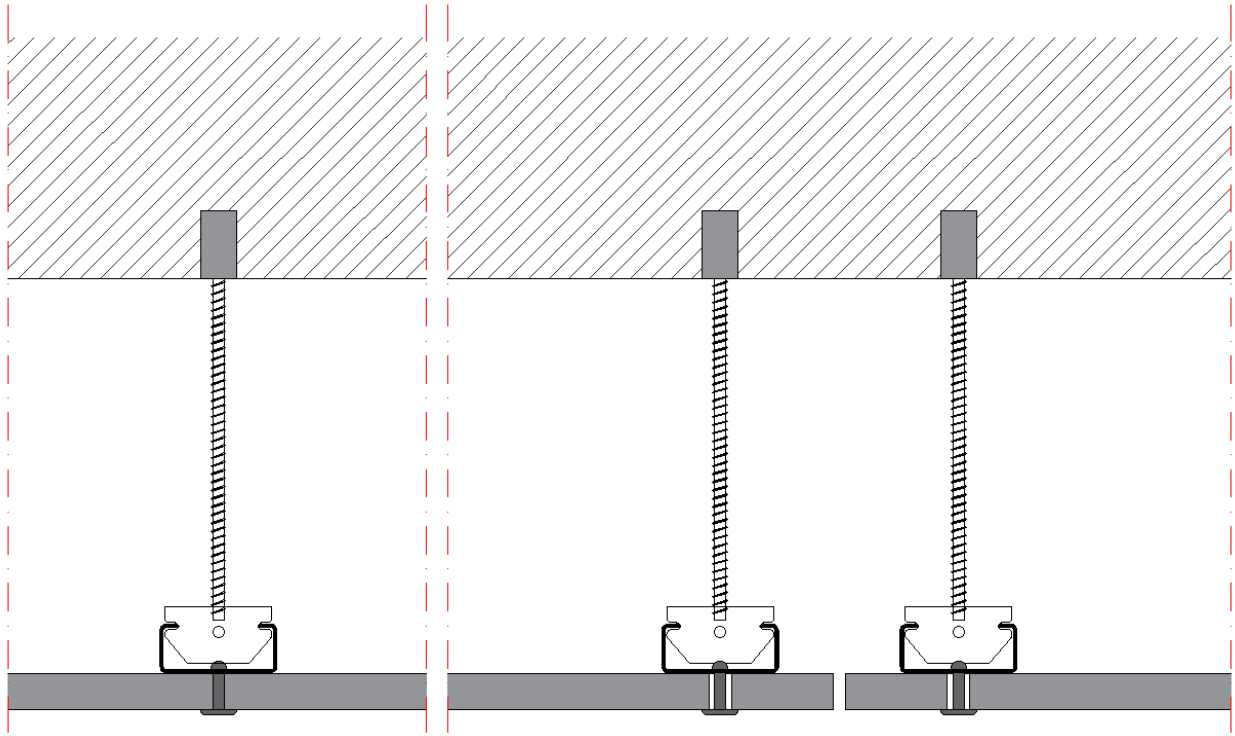

Figure 5.18 - Roof with galvanised steel TC structure

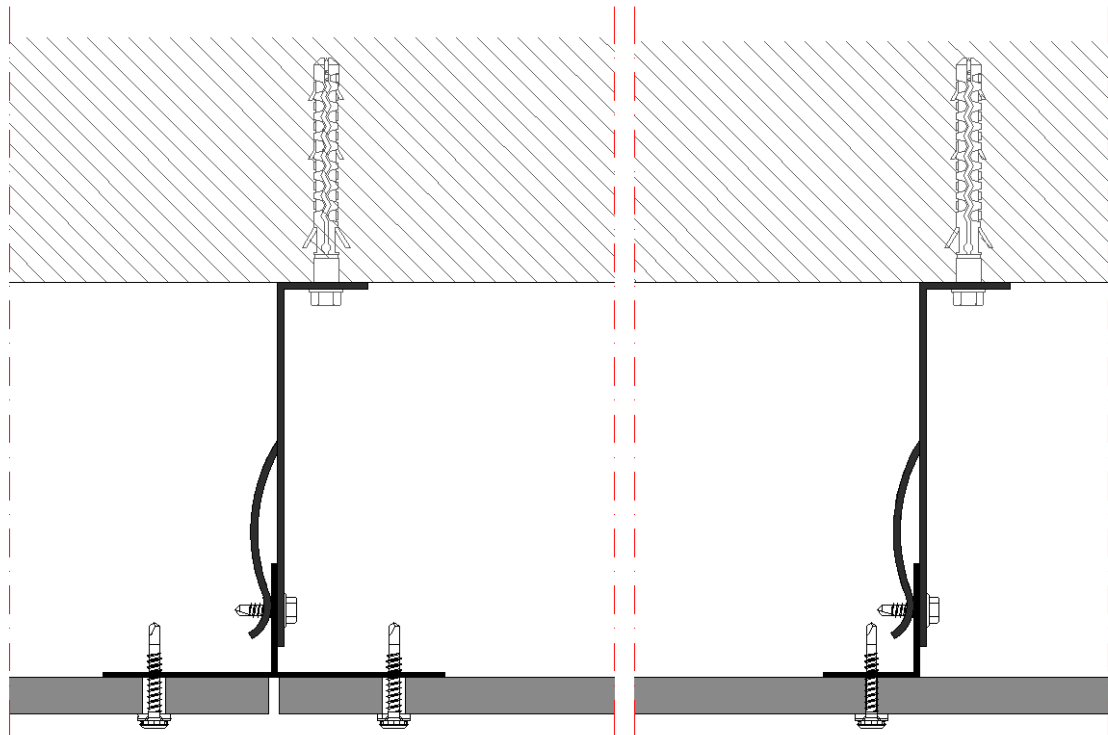

Figure 5.19 - Roof with aluminium structure

5.9 Acoustic performance

Viroc Portugal carried out some sound absorption tests, the performance of which has been characterised, with the geometry of the panels as shown in figures 5.20 and 5.21.

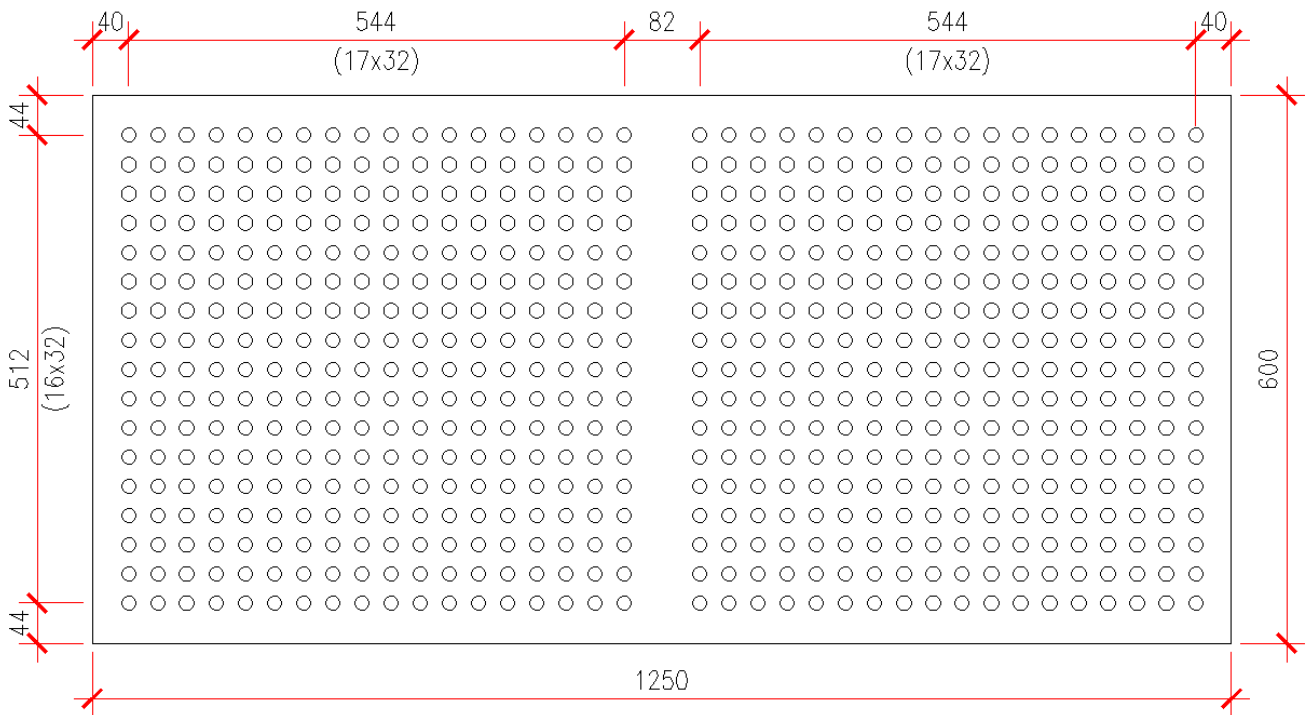

Figure 5.20 - Panel 1250x600 mm, with 12 mm diameter holes 32 mm apart between the axes

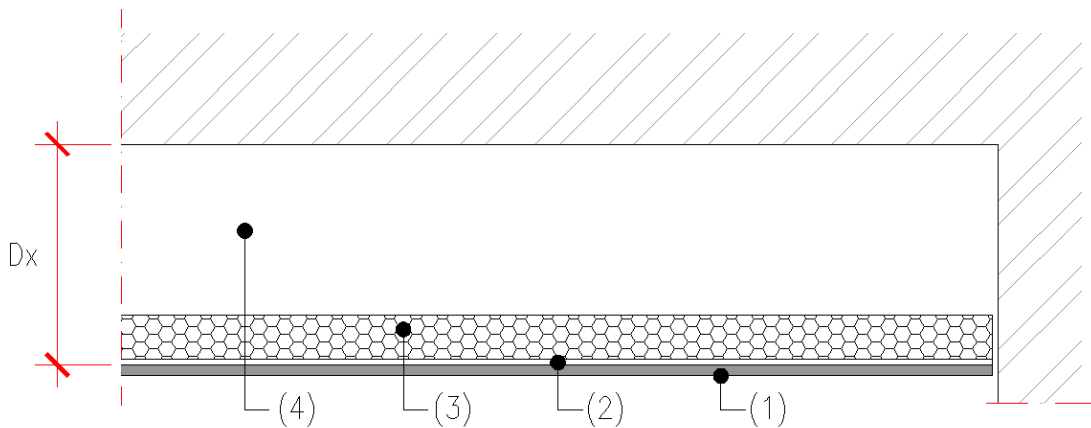
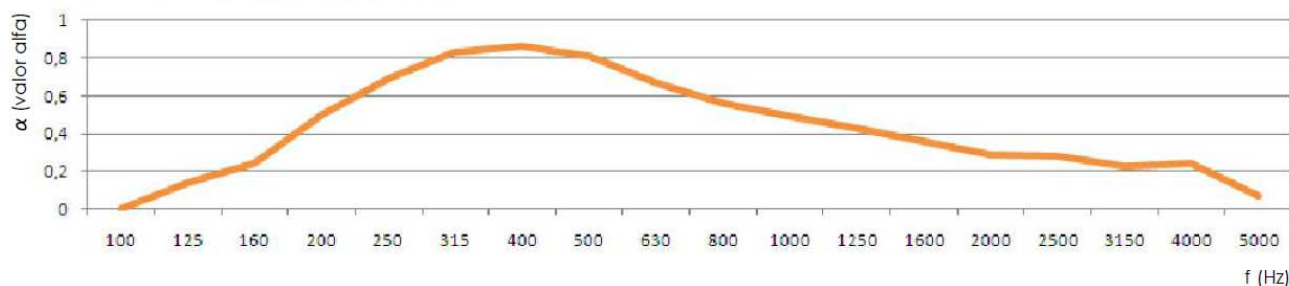

Figure 5.21 - Ceiling section, from the experimental tests carried out to determine the sound absorption index

- 1) Viroc panel
- 2) Acoustic felt
- 3) Rock wool, thickness 40 mm, density 30 Kg/m³
- 4) Air gap, Dx =100, 200 and 400 mm

5.9.1 Ceiling with 100 mm box (Dx=100 mm)

ÍNDICE DE ABSORÇÃO SONORA



f (Hz)	100	125	160	200	250	315	400	500	630	800	1000	1250	1600	2000	2500	3150	4000	5000
α (alfa)	0.00	0.14	0.24	0.50	0.69	0.83	0.86	0.81	0.67	0.56	0.49	0.43	0.36	0.29	0.28	0.23	0.24	0.07

5.9.2 Ceiling with 200 mm box (Dx=200 mm)

ÍNDICE DE ABSORÇÃO SONORA

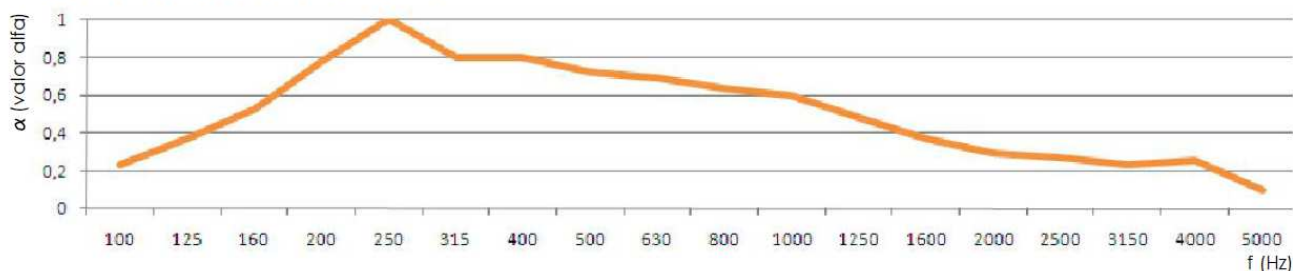

f (Hz)	100	125	160	200	250	315	400	500	630	800	1000	1250	1600	2000	2500	3150	4000	5000
α (alfa)	0.23	0.37	0.53	0.78	1.00	0.80	0.80	0.72	0.69	0.64	0.60	0.48	0.37	0.29	0.27	0.23	0.25	0.10

5.9.3 Ceiling with 400 mm box (Dx=400 mm)

ÍNDICE DE ABSORÇÃO SONORA

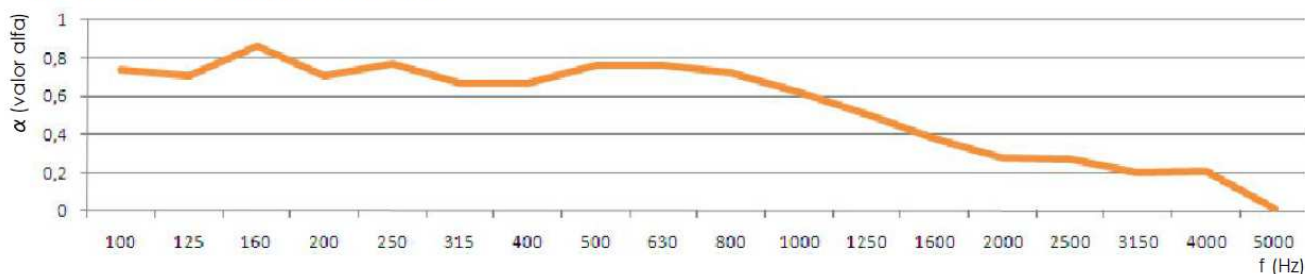

f (Hz)	100	125	160	200	250	315	400	500	630	800	1000	1250	1600	2000	2500	3150	4000	5000
α (alfa)	0.74	0.71	0.86	0.71	0.77	0.67	0.67	0.76	0.76	0.72	0.62	0.50	0.38	0.28	0.27	0.20	0.21	0.01